

Training Course on the Conservation of Cultural Heritage in Asia and the Pacific 2003

The Preservation and Restoration of Wooden Structures

Lecture

Design for the Reconstruction of Ancient Buildings
at the Nara Palace Site

September 29, 2003

SHIMIZU Shigeatsu
Architectural History section,
Department of Cultural Heritage
National Research Institute for Cultural Properties, Nara

Introduction: Reconstruction Policies of the Nara Palace Site

Numerous reconstruction policies govern the Nara Palace Site. The Nara Palace Site has been designated as a Special Historic Site by the Japanese government. The Nara National Research Institute for Cultural Properties has provided expert advice on the improvement and maintenance of this site, and has been involved in the design for reconstruction work, which will be carried by the Agency for Cultural Affairs (ACA). The reconstruction of the First Daigokuden Hall (Imperial Audience Hall) and the Daigokuden'in (Complex of Imperial audience Hall) has now commenced. The following are extracts from a planning meeting report for the Daigokuden reconstruction in 1993. It outlines a number of reconstruction policies:

1. The First Daigokuden Hall should be reconstructed as a building with a dignified appearance worthy of being a core facility of the palace site, which has been maintained in its entirety as a site museum as outlined in the *Basic Scheme for the Preservation, Improvement and Maintenance of Nara Palace Site*.
2. Concerning the reconstruction, it should be faithful to the structure and design of the original building based on historical evidences and research gathered.
3. Reconstruction of the First Daigokuden Hall should be completed without disturbing any unearthed archaeological remains in the ground.
4. Reconstruction of the Daigokuden, which is the main structure in the complex, should be prioritized. Other buildings of the complex such as gates, guard towers and cloisters will be subsequently reconstructed to recreate the whole Daigokuden'in complex as a faithful model of a Nara-period palace. This site could then serve to provide a vivid historical experience.
5. The reconstructed structures should not be conceived simply for general viewing, but as multi-purpose, interactive facilities which people from various backgrounds can understand and appreciate.
6. The preservation and maintenance of the reconstructed building should incorporate all measures to support its unique role as a heritage museum.
7. The improvement and maintenance of the Nara Palace as a Special Historic Site should draw the support and understanding of the local community and the entire Japanese nation.

The policies outlined above were based on the *Basic Scheme for the Preservation and Development of the Nara Palace Site as a Special Historic Site*, adopted in 1978. Conforming to this scheme, the Daigokuden reconstruction policy includes elements that do not necessarily match modern thinking. For example, regarding the method of reconstruction, it is simple enough to specify "exact reconstruction," yet everyone participating in the design knows quite well that this is in reality not possible. Further, while it may be possible in some sense to create a "model of a Nara-period palace that will provide a vivid historical experience," such a goal is actually very difficult to attain, because a reconstruction serves to fix in place a historical image that leaves little room for the exercise of the imagination.

The reconstruction of architectural ruins has already been carried out at numerous locations in Japan. However, little consideration has been given to the theoretical issues surrounding the act of reconstruction. The time has come for architectural reconstruction to be examined critically. I will take this opportunity to survey both the merits and demerits of architectural reconstructions in Japan, with a view to propose how reconstructions ought to be carried out in the future.

1. Premises for Reconstruction in Japan

• Criticisms for Reconstruction

The reconstruction of lost structures on ancient sites is excluded *a priori* from the Venice Charter; in Europe the concept has been roundly criticized during discussions since the 19th century. Yet since the 1990s the world has seen a boom in reconstruction projects. The question of whether the practice of reconstruction in Japan is related to that global trend is one that still requires discussion. Yet what may be called the mainstream of reconstruction projects in Japan has been carried out since the 1960s; hence this area of work represents a unique Japanese enterprise. Why is it that Japan proceeds with architectural reconstruction, oblivious of the critical mood in Europe?

• The Nature of Architectural Remains in Japan

One of the key features of ancient remains in Japan is that there are no "ruins." The idea of a "ruin" is applicable to cultures with stone structures, where the building in its basic form remains even after its functional life is over. Hence ruins typically have a romantic connotation quite distinct from ordinary buildings.

The wooden buildings of Japan, once vacated, were destroyed or else with the passage of time, deteriorate and completely disappear as they rot away. What faint traces of the buildings that do remain buried in the ground are extremely fragile. With nothing concrete to actually set one's hands on, ancient sites in Japan consist of little more than empty expanses of land, where without conducting archaeological excavations and investigations, information about the former appearances of a historical site is extremely limited. Consequently, historic sites in Japan evoke an acknowledgement of the transience of things. This has contributed to the cultivation of a literary tradition in Japan, where the former appearance of ancient sites are often vividly described based on the imagination. Indeed, one major role played by ancient sites has been just such stimulation of the literary imagination. With that sort of cultural tradition, the act of reconstructing an ancient building in Japan runs the risk of concretizing a static historical image, whereby leaving little room for the imagination.

In reconstruction projects, it is therefore important to consider the evocative power of an ancient site; reconstructions should serve to enhance this power. A balance is required between the preservation of a site and its utilization. To what extent are current reconstruction projects informed by such consciousness? We must reflect on this point.

• **The Characteristics of Wooden Buildings in Japan**

In Japan, there are many existing wooden structures from the Nara period and earlier, one notable example is the Horyuji temple, where existing buildings date from the seventh century AD. These structures have common characteristics in their basic structural and detail designs, while structural limitations are posed by the materials used and the nature of the wooden components. Wooden buildings in Japan were based on a structural system that can be rationalized. This system consists of fitting together wooden members, hence to a degree there is little room for freedom in design. The dimensions of members cannot be arbitrary determined, and for the most part, carpentry methods were strictly specified. The construction of wooden buildings was therefore a very standardized field. Moreover, the rationalization of timber construction gave rise to a system known as "*kiwari*" (timber proportions). Under the *Kiwari* system, the proportions of all wooden members are standardized. Since large buildings such as palaces and temples were erected under the direction of the centralized state powers, their architectural forms were disseminated throughout Japan, and buildings acquired an aspect of formal uniformity.

Due to the practice of standardized construction techniques which resulted in similar architectural forms, it is possible to extrapolate the appearance of historic buildings in the absence of actual physical remains in Japan.

• **The Purpose of Reconstruction**

From the perspective of the conservation of ancient historical sites, two purposes for architectural reconstruction may be identified:

- 1) Site development (i.e. presentation)
- 2) To achieve an understanding of history via the physical experience of a site

On Japanese historical sites where few remains are visible, and where the site in itself has very little visual indications of its history, the development of the site for appropriate activities takes on an especially strong significance. Architectural reconstruction has become the main strategy for the development of historic sites. However, from the perspective of architectural preservation, certain aspects of the current practice of reconstruction in Japan cannot be met with wholehearted approval.

2. Methodology for Reconstruction Design

• Methods of Reconstruction Design

1. Remains, relics (tile, metal fittings, post bases, etc.), historical records and art works serve as the basis for reconstruction design.
2. The form, structure and detail designs of historic architecture are derived from extant remains and research into the construction techniques at the time.
3. The reconstruction design of the superstructures must incorporate various considerations. While the basic form of a building is determined by studying the ancient construction systems that had been employed, the structural design of the reconstructed building must take into account environment factors, and possible deformations due to dead load and the passage of time. On top of this, the construction techniques to be employed, the style and details of the building must also be considered.
4. Structural reinforcement is provided to meet safety standards and to ensure the longevity of the reconstructed building.

Designs for the superstructure that have been derived from direct archaeological evidence and remains rarely conform to standardized models of the same typology. Therefore, we can not rely exclusively on physical evidence and remains, but must take into consideration the ancient construction systems and the standardized designs applied in the past. We need to exercise creativity in designing reconstructions.

Let's consider the design of the roof for example. The roofs of ancient timber structures take a relatively simple form; they are supported by columns and feature a typical pitch and eave projection. With further site investigations, we can accurately approximate the appearance of the roof. Excavated tiles provide an indication of the pitch of the roof, while the distance of the eave projection can be derived from the location of excavated stone rainwater ditches. Having approximated the size of the roof, its probable structure and the location of columns can be determined. The style, form and size of ancient buildings reflect their functions and relative status, and the construction and design of buildings were regulated by a standardized system. Therefore, by determining the dimensions of one part of a building, the other parts can be deduced.

The dimension of columns can be easily determined in reconstruction design. Since the height and diameter of columns are relative to their spacing, by determining the column spacing, other dimensions can be derived.

• **Unobtainable information**

While this deductive method based on historical resources is a great tool in reconstruction design, there are cases in which it is inadequate.

For example, we encountered a dilemma in determining whether the Suzaku Gate at the Nara Palace site was single or double storied. Since there was no tangible evidence from the site, we considered its context and status within the Nara palace site, and researched about known examples within this typology of construction. The Suzaku Gate in Heiankyo (Kyoto) from a later period was taken as an appropriate model for a palace gate, and consequently a double storied structure was determined for the reconstruction (Figures 1a and 1b). In reconstruction design, we often encounter the problem of missing information, and must use other methods to overcome such barriers. In Japan, missing information has often been filled in by studying known examples, however, such practices have been critically rejected in Europe since the 19th century.

• **The Practice of Reconstruction Design**

Case study: The reconstruction of the Corner Tower of the To'in Garden

The corner tower of the To'in Garden is a particularly unusual structure situated at the projecting southeastern part of the palace site (Figures 2 and 3). Remains from the later half of the 8th c. had been discovered at the southeast corner of an area that was a garden attached to the palace (Figure 4). During an excavation in 1967, 11 large postholes were discovered with the stone bases and posts still inside (Figure 5). The foundation stones were about the size of a human head; the posts had holes near the base for horizontal members to pass through, and there were cross ties between the horizontal members (Figure 6). Such sturdy groundwork suggested that the supported load was quite large, hence a multi-storey building was hypothesized, leading to the image of a tower pavilion at the corner of the garden.

A total of five ideas had been proposed for the design of the superstructure at various stages based on the evidence available at the time. Both an octagonal and a square tower with an eastern and southern projection had been proposed initially. However, an excavation in 1997 showed that there were no such projections. It was then proposed that the structure had a square plan and featured overhanging eaves on two sides, as suggested by the distribution of the footings.

Such forms of buildings usually featured overhanging eaves on the north and east sides, which could've easily been supported on small posts. However, the excavated footings were equally well reinforced, thus casting doubt on the validity of this scheme.

The Phoenix Hall at the Byodoin temple in Kyoto (Figure 7) was then examined as a model from the same typology. Subsequently, an L-shaped gallery with a square, double storey structure at the corner was next proposed. In this case, the weight of the second storey is uniformly distributed onto the lower level, which conforms to the nature of the excavated footings. The roof of such an L-shaped structure was usually supported with a curved beam placed at 45° angle at the corner, as in the case of Phoenix Hall. Internal columns are eliminated in this construction method, whereby freeing the interior space (Figure 8a). However, an extra footing that was excavated at position C2 led to a revision of the structural configuration and roof form that was based on Phoenix Hall. Finally, a satisfactory proposal was produced. The final design suggested a building with a main east-west axis, which was defined by the division of space within the structure. The location of a column at C2 defined the northern extension of the building as a subsidiary space. (Figures 8b and 9)

When the basic form of the building had been determined, the details were considered. The roof was presumed to be of cypress bark shingles since very few roof tiles had been unearthed while there were remains of cypress bark. Floor struts had not been found on site; thus it was deduced that the lower level might have featured an earthen floor as an extension of the garden path.

This case study highlighted the advantage of using typological studies as an aid for interpreting excavated remains. Yet it must be recognized that there can never be absolute certainty to the accuracy of a reconstruction due to various limitations in the data available. We can only derive a most probable design from the sources of information available. Through this process of analysis and research, we can better understand about the nature of ancient buildings during reconstruction design.

3. Learning about Ancient Architecture through Reconstruction Design

Among the investigative work conducted in the course of designing the reconstructions on the Nara Palace site, the best results had been derived from analyzing the structure of ancient buildings and construction technology.

• **Structural Investigations of Ancient Architecture**

Case study: Daigokuden, Nara Palace Site

A double storey building was proposed for the reconstruction of the Daigokuden (Imperial Audience Hall), necessitating the design of a very complex structure (Figures 10). There is no historic precedent of a double storey building of a scale comparable to that of the Daigokuden. Investigations were undertaken to determine a probable structural design for this buildings.

The main hall and inner gate at Horyuji Temple (Nara) both feature two levels, but the daigokuden is of a much larger scale with a floor area that is 6.5 times larger and column spacing that's 1.6 times that of the Horyuji buildings. A simple adaptation is thus not possible. The main hall of the Toshodaiji temple is of comparable size, and had been adopted as a model structure to which a second storey might be added, but it was found that the load from the upper storey could not be transmitted efficiently to the lower structure in this model. (Figure 11)

Various historic buildings were then examined for further structural insight; in particular the main hall at Horyuji temple was analyzed (Figure 12). This study revealed that from the overall structure to their details, the design of all extant historic buildings in Japan was based on a structural rationale. Every component of a building had a structural purpose. The following observations were made:

- Transmission of loads in two-storey buildings
- structural techniques employed in buildings featuring three-tiered eave
- Classification of buildings by whether or not the perimeter columns are the same height as the internal columns
- Role of the ceiling as a horizontal structural plane
- Role of timber structural brackets

• **Construction Technology of Ancient Architecture**

The reconstruction and restoration of historic buildings are quite distinct from each other and have different design requirements. The design, use of materials and structure of historic buildings must be well understood. Extant historic architecture presents an excellent opportunity for studies into ancient structural techniques. An understanding of structural techniques provides a better understanding of the aesthetics of ancient buildings. For example, the following have been observed:

- The maximum member length in ancient buildings is 10 meters
- The relation between the flashing and the location of ornamental ridge-end tiles
(Figure 13)

4. Reconstructed Buildings and Contemporary Design

A building can be considered a living thing as its form and appearance change with time. However, a reconstructed building is intended as a representation of the architecture of a certain period, thus its form has to remain unchanged. In other words, it can be considered a dead building, or as a "full-scale model" that represents buildings of the past.

Two major problems arise in the reconstruction design of ancient buildings. One is that their original structural design of is usually deficient. Since medieval times, freestanding supports (*nogoya*) had to be added to hold up eaves with large overhangs, since deformation often occurred due to inadequate structural support. For example, the extant main hall at Toshodaiji temple now has notable structural deformation, where inward inclination of columns has occurred due to the load of the roof overhang.

The other problem is that ancient buildings were not necessarily built to last a long time. However a reconstructed building today cannot be designed with a short service life, especially since they're especially commissioned by the national government.

Although the analogy of a "full-scale model" was used, a reconstructed building is actually used by people and designed for a specific purpose, thus it must also conform to current construction laws. It must be designed to ensure safety and longevity. Thus, in addition to the issue of academic authenticity, reconstruction projects embody practical problems and conflict of intentions.

• Structural Reinforcement

Structural reinforcement must be incorporated in order to comply with current construction standards and law. There are two basic approaches to this requirement.

1. Provide reinforcement using traditional techniques. As this involves the inclusion of additional cantilevered structures and freestanding eave supports, the original appearance of an ancient building cannot be maintained. This technique had been utilized in the reconstruction of the Suzaku Gate.
2. Provide reinforcement using modern technology. The original appearance of a building can be recreated, but this involves complex design. For example, many additional bracings have been applied to the roof structure of the Suzaku Gate (Figure ?). In the Daigokuden Hall, the superstructure is structurally isolated from the podium, and the podium is hollow with seismic prevention technologies in place. The structure has been designed to withstand its own weight, as well as seismic and wind forces.

As a rule, reinforcements are hidden from view so that the original appearance of the building can be recreated. The reinforcing elements are also placed in such a way that they can be removed in order to satisfy the criterion of reversibility.

• **The Conflict between Legal Compliance and Classical Construction**

In the enforcement of current building standards, the nature of classical constructions is often compromised. One main difference is the level of precision applied. In ancient times, precision was given little emphasis in carpentry, and there were variations of quality between tiles and other materials. To overcome such inconsistencies, everything was made to fit together on site. The resulting form of ancient buildings is thus endowed with a sense of tension. Nowadays, compliance with current building standards and construction law means that the lack of precision or uniformity is not tolerated. The result is a building that feels highly refined, which conflicts with the spirit of an ancient building.

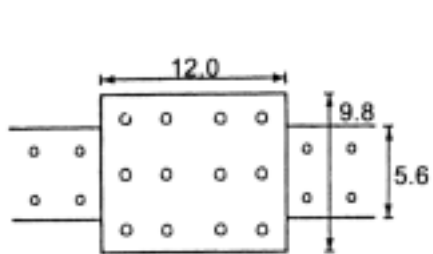

Kibi-ike haiji Temple
(吉備池鹿寺)

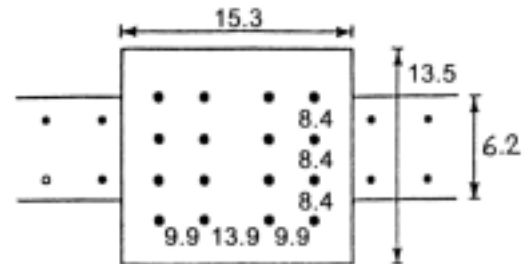

Asukadera Temple (End of the 6th century)
(飛鳥寺)

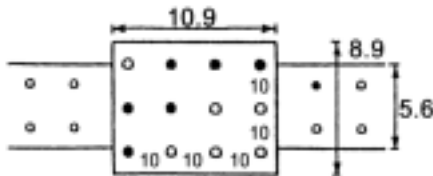

Tachibanadera Temple
(橋寺)

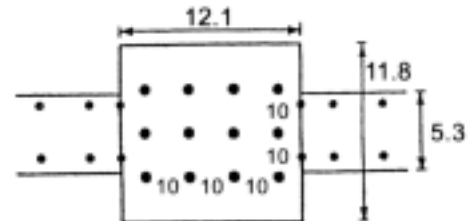

Shiten-no-ji Temple
(四天王寺)

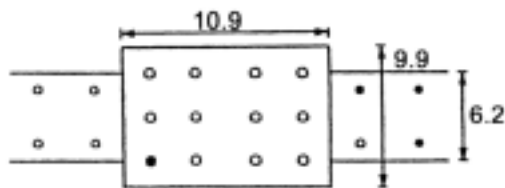

Kawaharadera Temple
(川原寺)

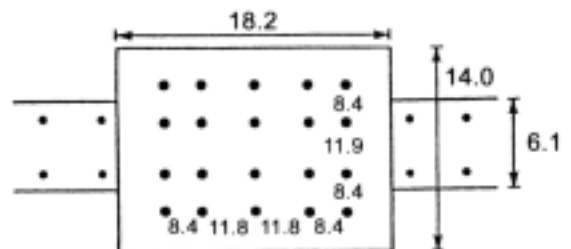

Horyuji Temple (End of the 7th century)
(法隆寺)

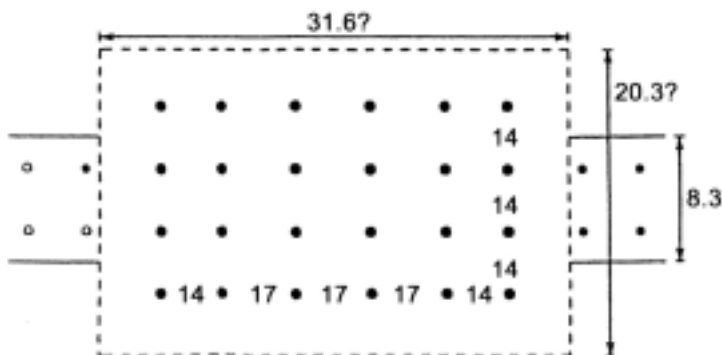

Daikan-daiji Temple (Destroyed by fire in 711)
(大官大寺)

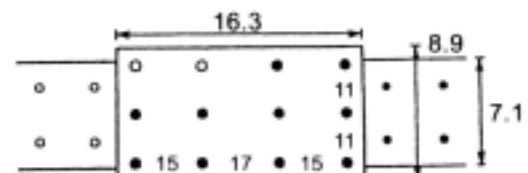

Motoyakushiji Temple
(本薬師寺)

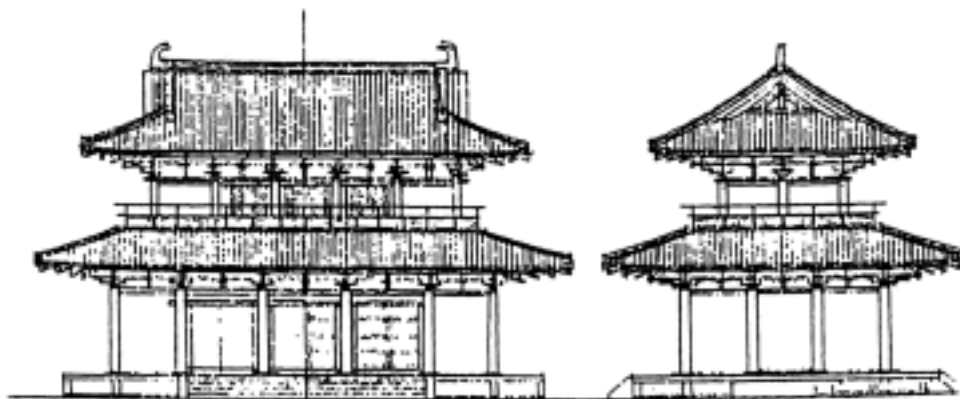

Central Gate of Daikandaiji Temple
Elevations (Reconstruction Drawings)



Central Gate of Horyuji Temple
Section (Reconstruction Drawings)

Fig.1a Studies of Main gates of temples in the 7th century (1/500)

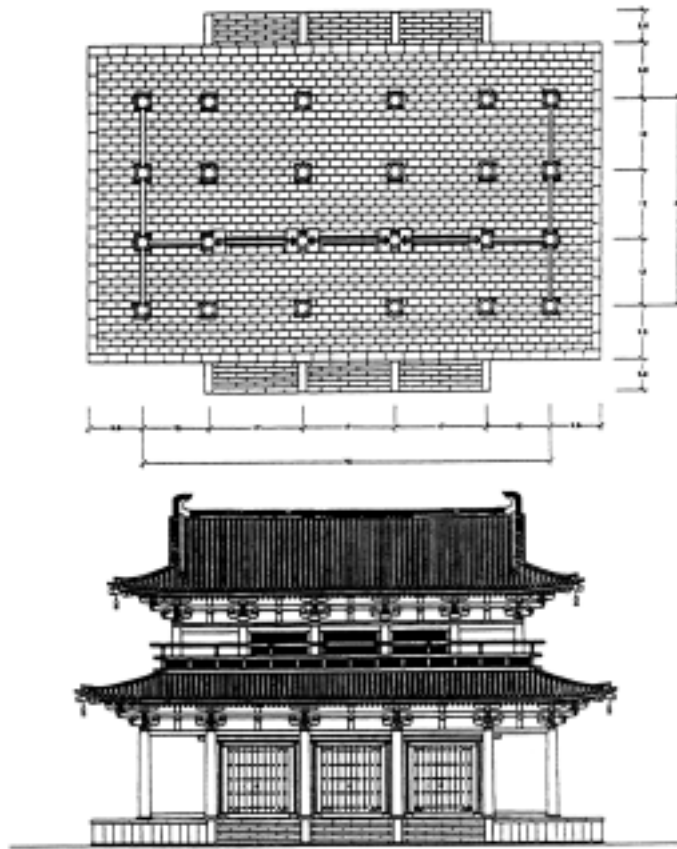

Fig.1b Reconstruction Plans for the South Gate of the Former Imperial Audience Hall (Daigokuden)

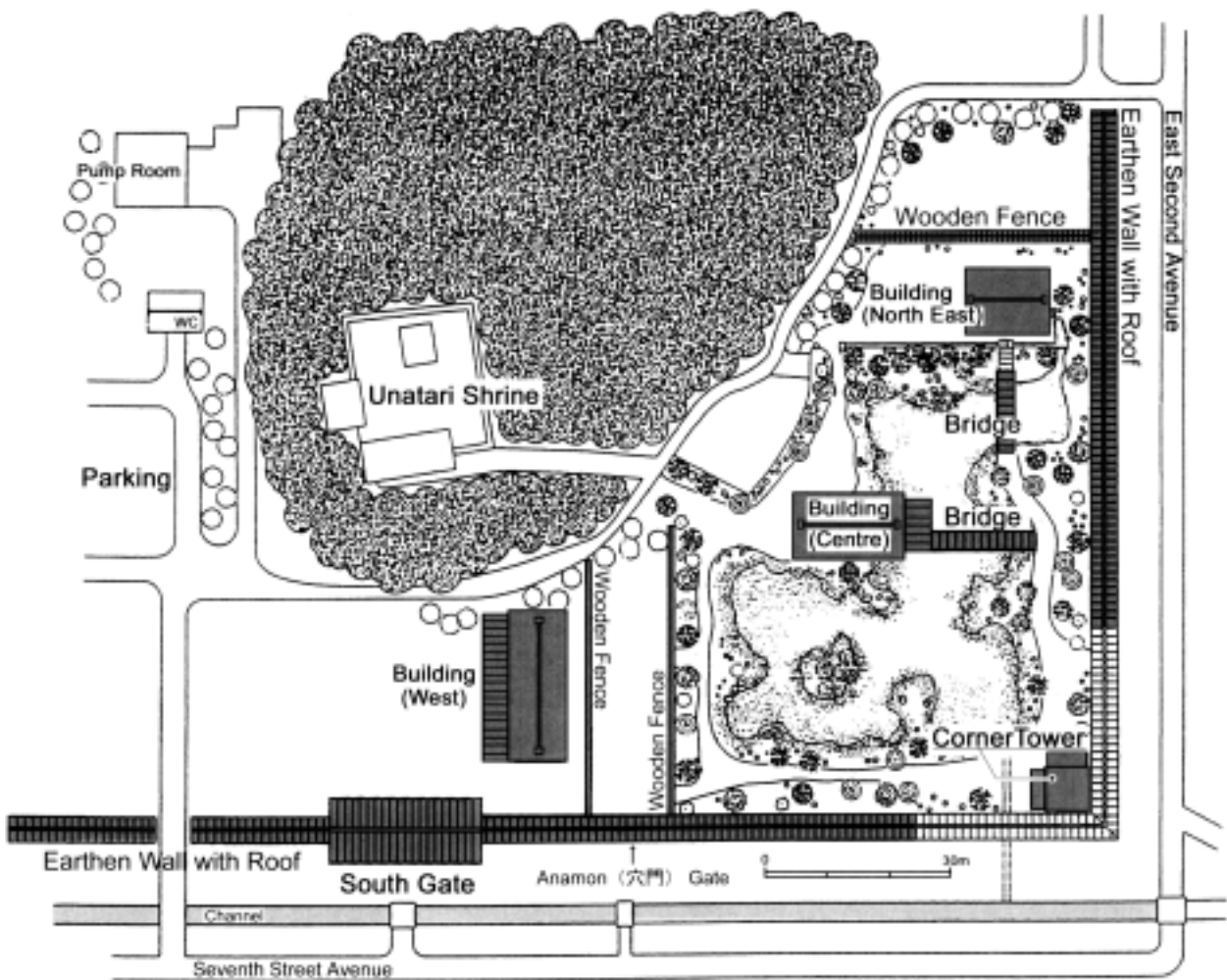
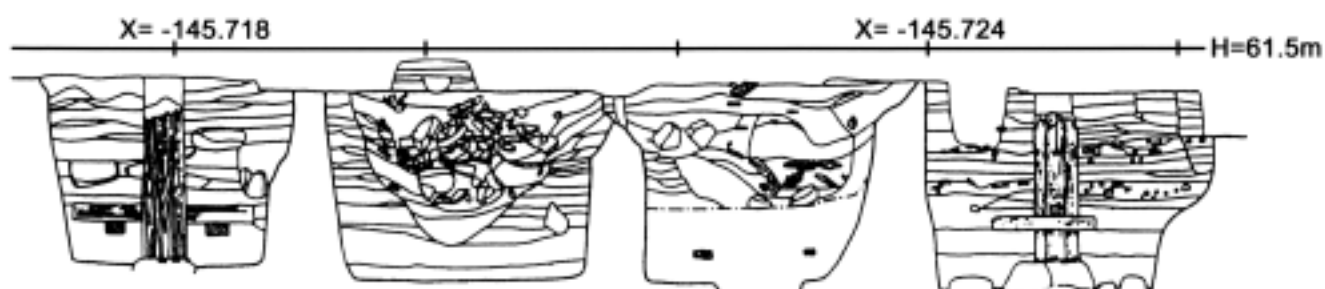
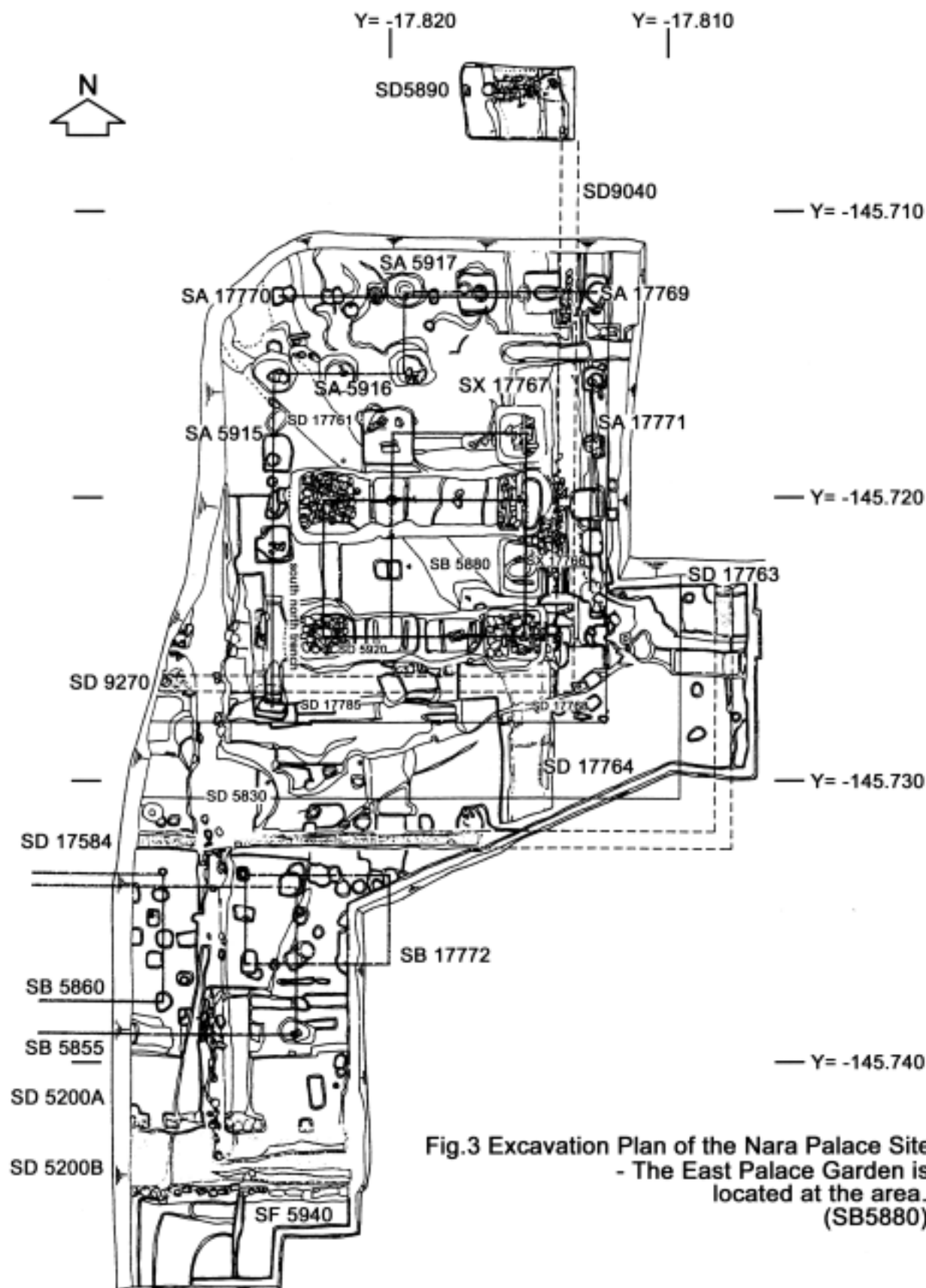

Fig.2 Site Plan of the East Palace Garden



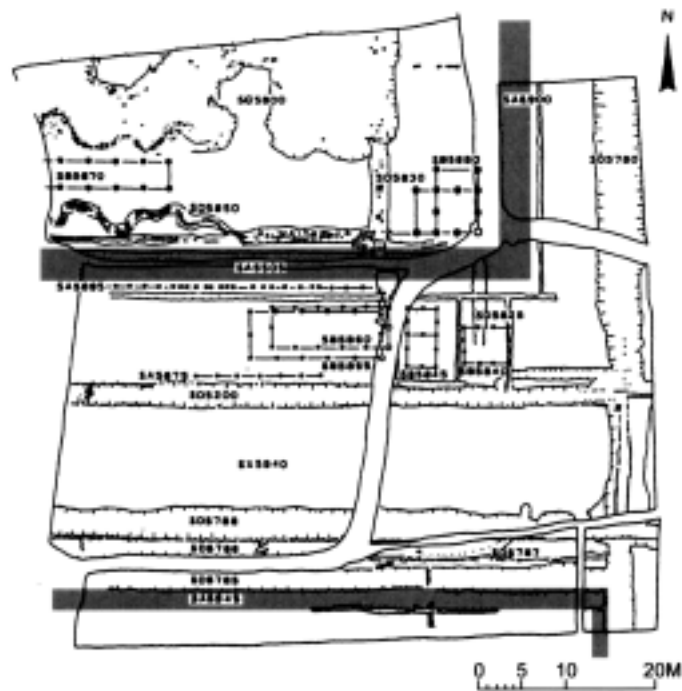
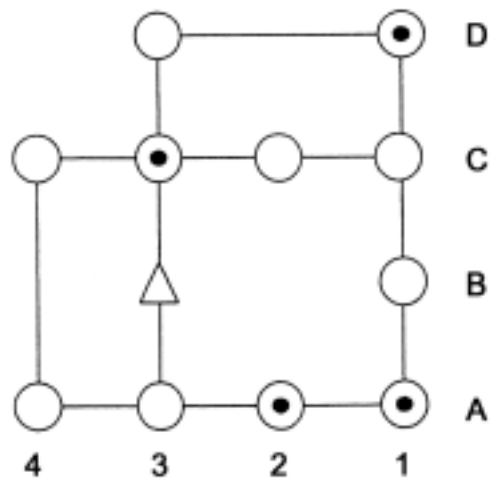

Fig.4 Plan of Excavation Locations at the East Palace Garden



LEGEND

- ⊙ excavated footing with remains of timber column
- excavated footing for timber column
- △ small hall

Fig.5 Location of the remains of the Corner Tower in the EastPalace Garden



Fig.7 Ho-o-do, Byodoin Temple

Roof Structural Plan

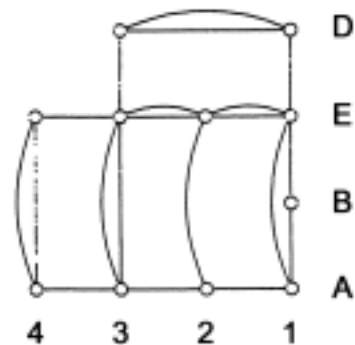
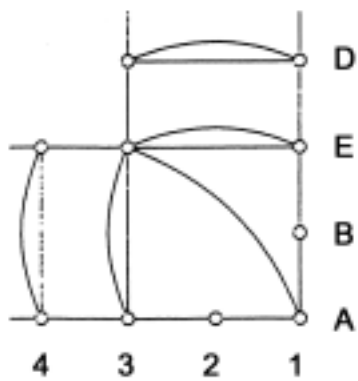

Roof Plan

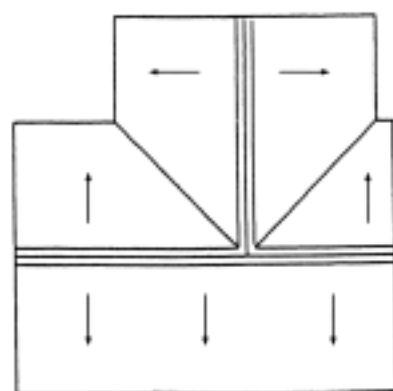
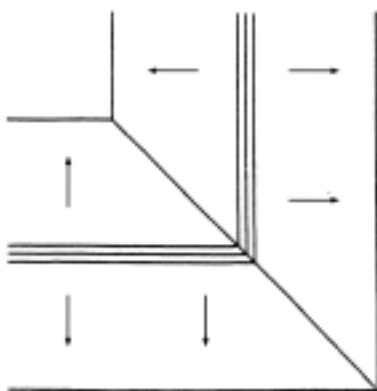
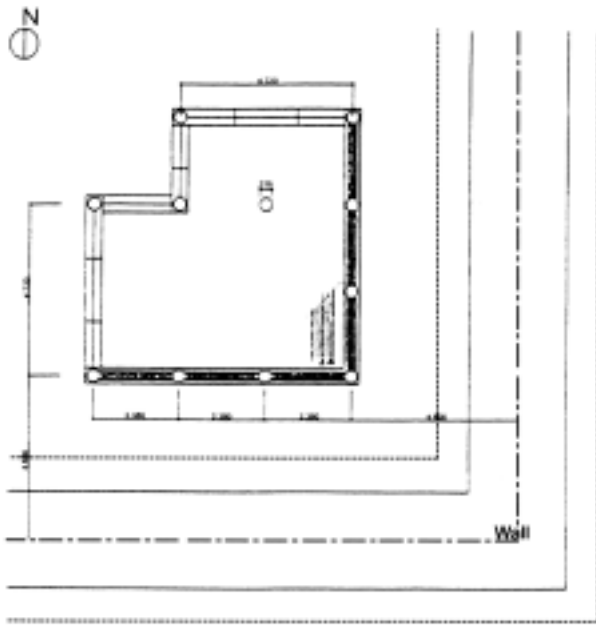

Fig.8a Roof Plan of typical L-shaped gallery

Fig.8b Devised Proposal

Fig.8 Studies of Roof Structure for the East Palace Garden Corner Tower



First Floor Plan

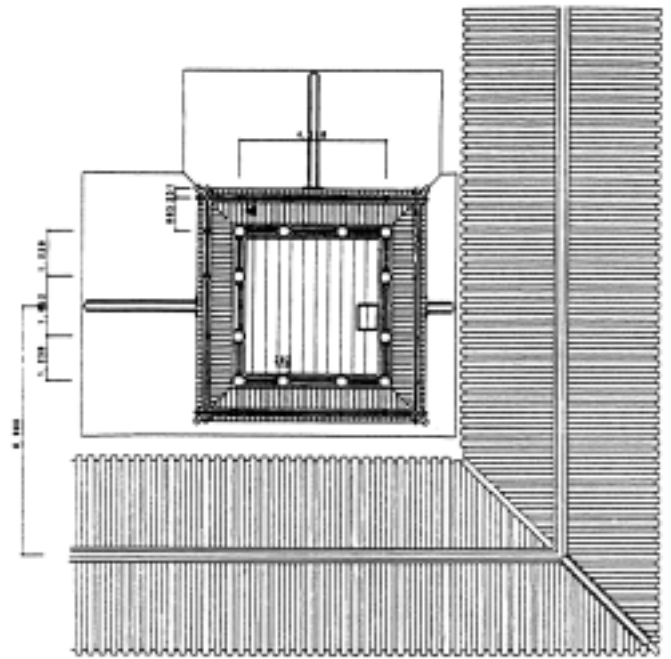

Second Floor Plan

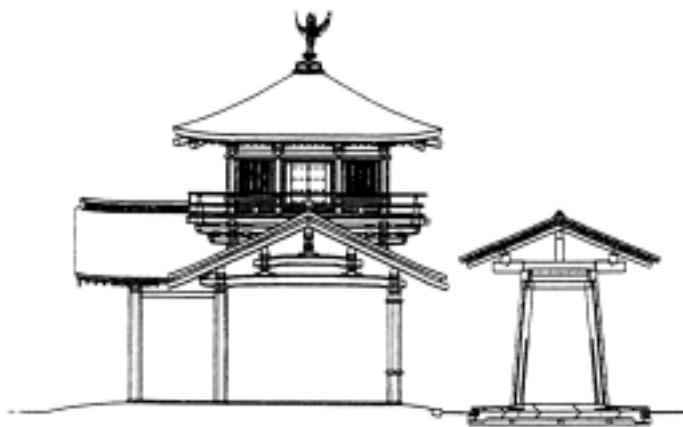

West Elevation

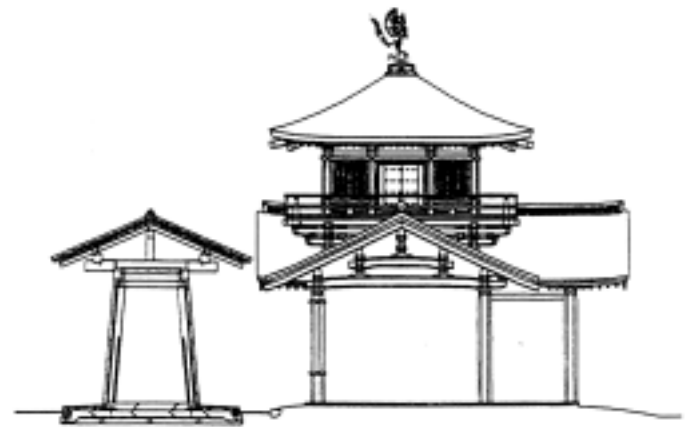

East Elevation

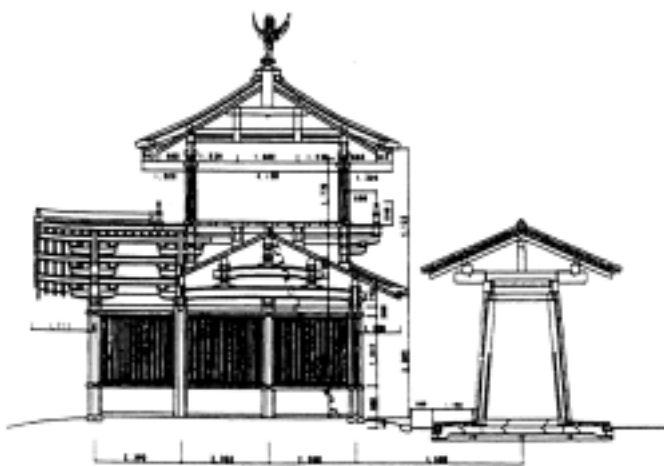

South-north Section

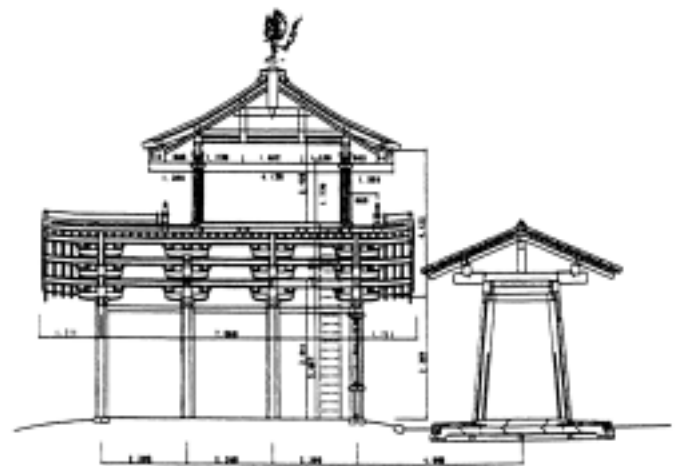

East-west Section

Fig.9 Reconstruction Design for the Corner Tower in the East Palace Garden

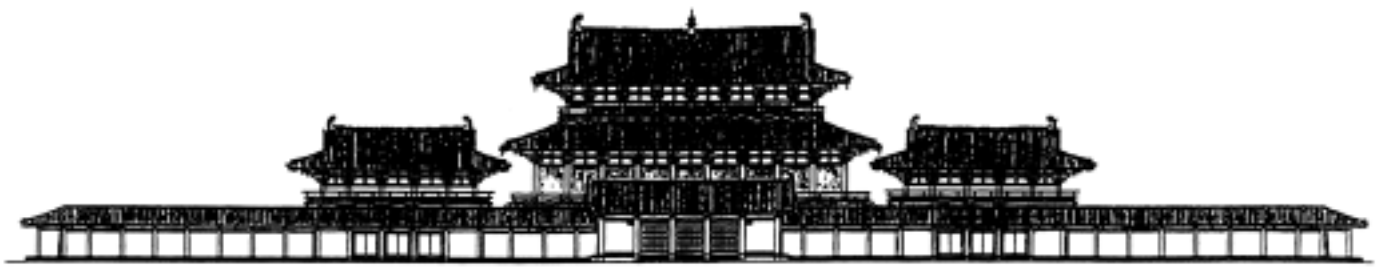
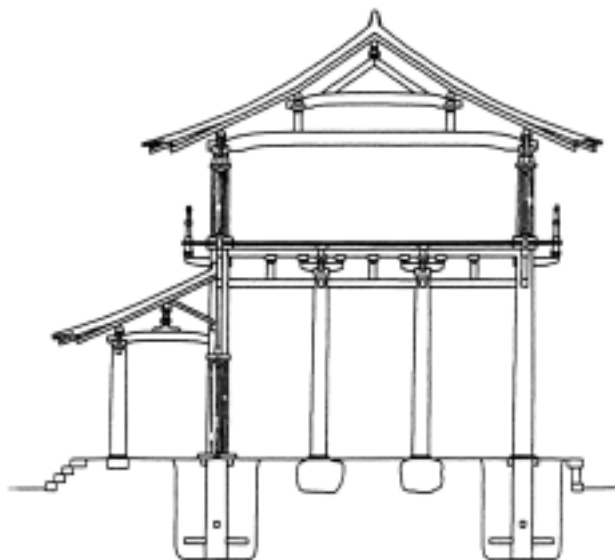
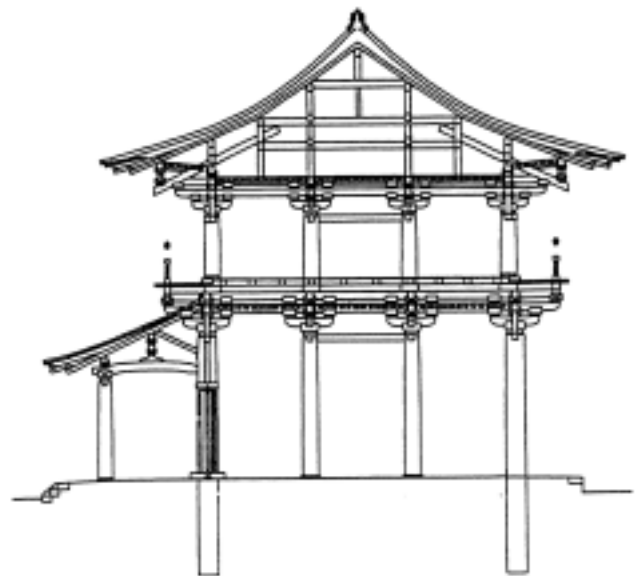

Fig.10 Proposed South Elevation for the Former Imperial Audience Hall

Study for the Reconstruction Plan of the East Tower of Daigokuden



Original Plan in 1982



Current Plan

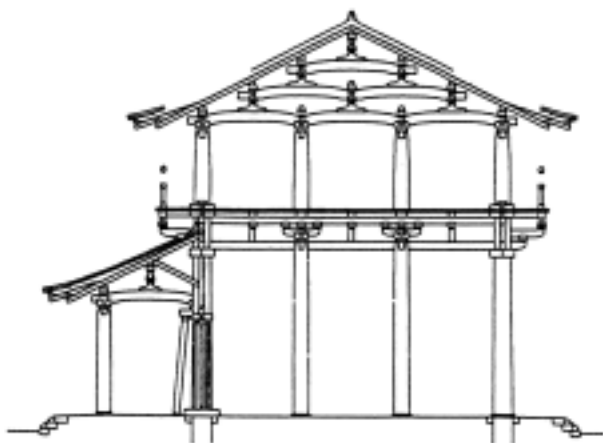

Plan for 1/100 Model in 1993

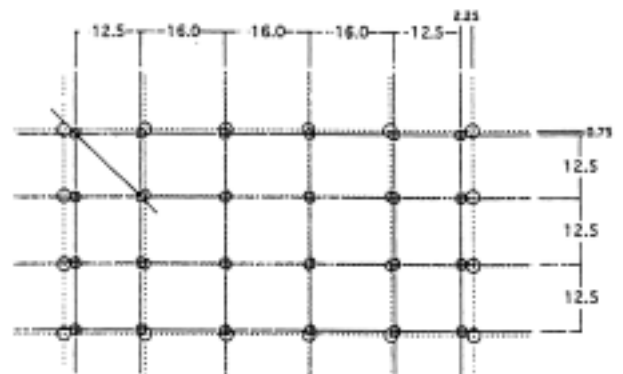

First Floor and Second Floor in the Current Plan

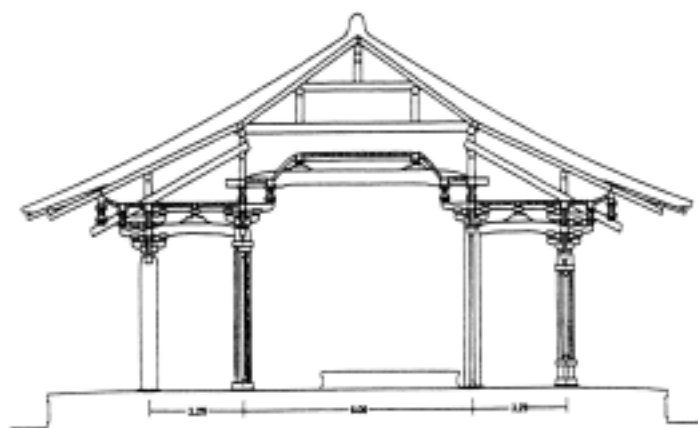

Main Hall, Toshodaiji Temple

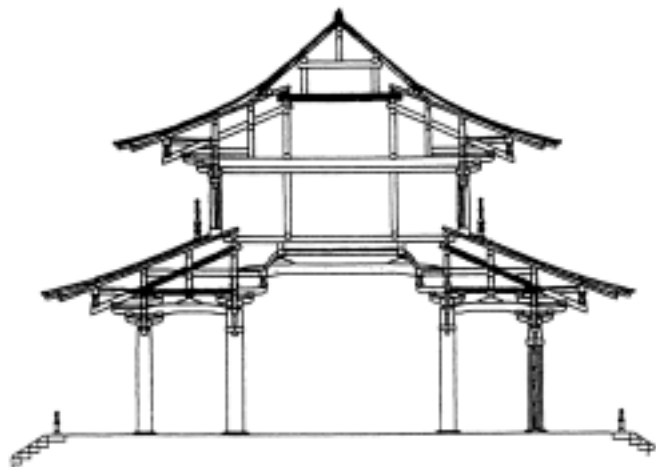

Plan for 1/10 Model

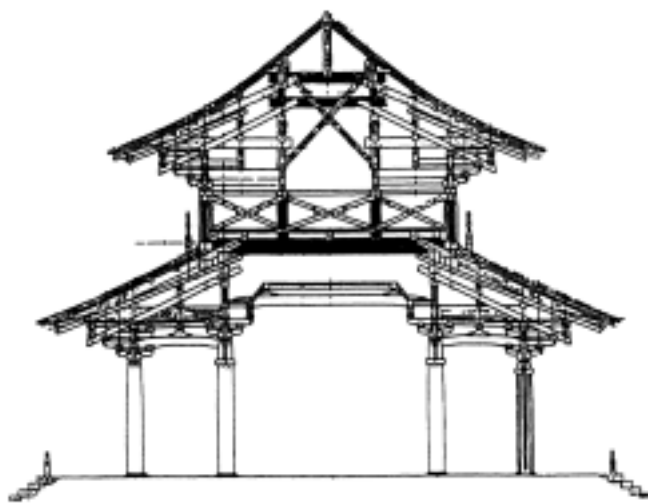

Reinforcement Plan for 1/10 Model Plan



Main Hall, Horyuji Temple



Original Plan for Enforcement



Working Plan

Fig.11 Studies for the Reconstruction of the Former Imperial Audience Hall (Daigokuden)

